



## VERSION HISTORY

File Number /Version	Issued By	Revision Date	Approved By	Approval Date	Adapted Pages	Reason
EMC-031-2016	Willems jan		Ivan Malfait			

File Number : EMC-031-2016

## CONTENTS

* <i>Front page</i>	<i>P 1</i>	
* <i>Revision history</i>	<i>P 2</i>	
* <i>Contents</i>	<i>P 3</i>	
* <i>Data Customer &amp; E.U.T.</i>	<i>P 4</i>	
* <u><i>Radiated emission</i></u>		
- <i>Test Setup</i>	<i>P 5</i>	
- <i>Used equipment</i>	<i>P 6</i>	
- <i>Overview Test Results</i>	<i>P 7</i>	
- <i>Test Results</i>	<i>P 8</i>	<i>~ 9</i>

(1) = Not under accreditation

FCD-0370/5

QP-0017

# TEST-PLAN

File Number : **EMC-031-2016**

## - Name and address of the customer .

Name : **ES Gear Ltd.**

Contact person : **Mr. Loic De Buck**

Witness during testing :

Address : **9B Amtel Buiding  
148 Des Voeux Road Central  
Hong Kong**

Tel/Fax : **BGEMC-16-030**

GSM : -----

BTW: -----

Offerte nr BGEMC :

Purchase Order: -----

## - Description of the E.U.T.

File number BGEMC lab: **EMC-031-2016**

Name : **Industruino**

Manufacturer/ Brand : -----

Type : **PROTO 1286**

Serial N°:

Quotation N° : -----

Part of : -----

Remark : -----

Short description of the functions : (photo) if applicable

**None**

PEMC date in :

PEMC date out :

Manual : **No**

## - Measurements according following standard(s) :

**EMC Compliant Testing according FCC Title 47. Part 15**

Radiated Emission

Section 15.109

ANSI C63.4:2014

120 Vac/60 Hz

## - Sampling method.

**None**

Sampling method :

If YES how :

## - Subcontracting.

**Yes**

Tests : **As customer required**

Name subcontractor :

## - Remarks and actions during measurements

### **Warning**

**This is a class A product. In a domestic environment this product may cause radio interference in which case the user may be required to take adequate measures.**

For contents of testplan Refer to QP-0017.

## - Uncertainty :

(if the measured value is within the uncertainty of the measuring system, the uncertainty will be indicated into this report. The judge Pass/Fail will not be indicated )

## - Temperature & humidity during measurements was between spec:

Humidity : min.: **30%**

max.: **70 %**

Actual **60%**

Temperature: min. : **18°C**

max.: **26 °C**

Actual **25°C**

Atmospheric pressure : **1011 hPa**

-----

Mains Voltage : **120VAC 60Hz**

-----

DC Voltage : -----

-----

### DRAWING AND/OR PICTURE OF TEST SETUP

Test system : **PEMC 01**  
According standard N° : **FCC15.109 Radiated Emissions**

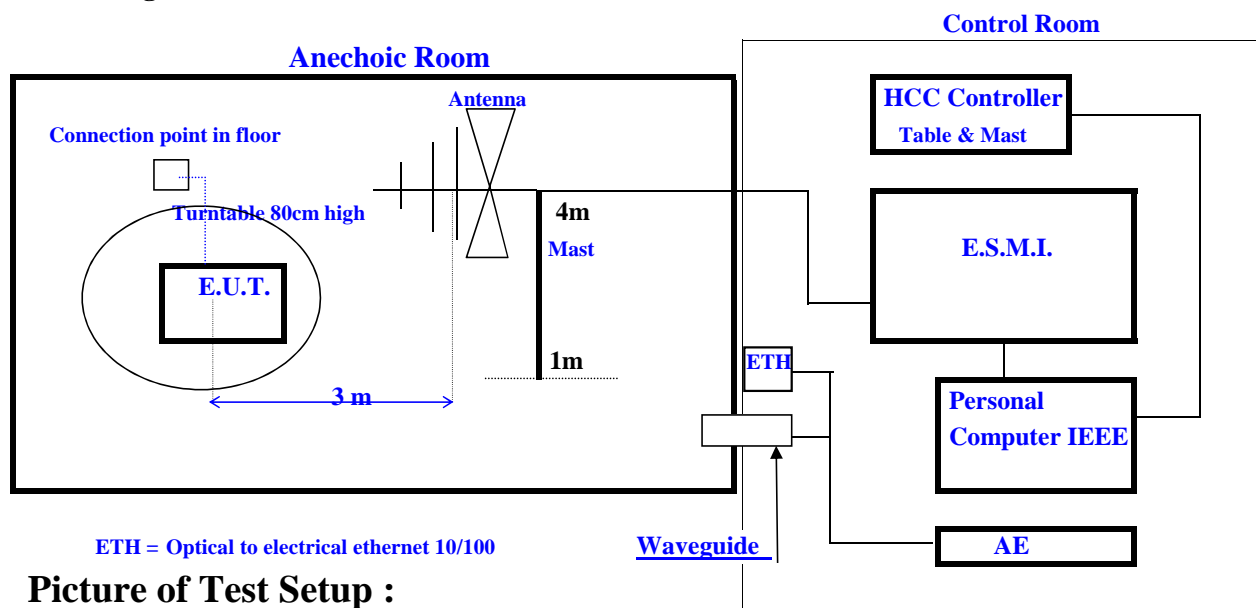

Picture of Test Setup :



## USED EQUIPMENT DURING MEASUREMENT

Test system : **PEMC 01**

According standard N° : **FCC15.109**

Pemc N°	Description /type	Type	Serial n°	Certificat n°
PEMC 01-001	Automatic turntable, wooden, d=1.2m	HCT12	835822/0006	-
PEMC 01-002	Automatic antenna mast, mobile, h=4m	HCM	836622/0009	-
PEMC 01-003K	Bilog antenna 30 MHz-1GHz	CBL6111A	1556	201403394.00
PEMC 01-004	Mast adapter for mounting the Bilog Antenna on the mast	CBL-MASTAD		-
PEMC 01-005K	Impedance transformer 50 <-> 75 Ohm	RAM	840946/0011	-----
PEMC 01-006K	LISN 9 KHz - 30 MHz 2 * 10A, TWO LINE V-NETWORK ESH3-Z5	ESH3-Z5	840730/001	BGEMC20130808.01
PEMC 01-007K	LISN 100 KHz - 200 MHz 100A, 600V DC ESH3-Z6	ESH3-Z6	840522/005	BGEMC2013823.01 + xxx
PEMC 01-014K	EMI test receiver 20 Hz - 26.5 GHz	ESMI	839699/0010 & 840498/004	201403395
PEMC 01-019	Mast & turntable positioning controller	HCC	840760/0001	-
PEMC 01-030	RF Cabling	TS-CABLRF1		-
PEMC-01-031	DC Power supply cabling	TS-CABLPS1		-
PEMC 01-032	AC Power supply cabling	TS-CABLAC		-
PEMC 01-033	Fiber optic cable Field Probe	TS-CABFO		-
PEMC 01-034	Fiber optic Cable Mast	TS-CABFO		-
PEMC 01-035	Fiber optic cable Turntable	TS-CABFO		-
PEMC 01-036	IEEE 488bus (2*PCK-1m) cabling	TS-CABLCO1		-
PEMC 01-038K	Pre-amplifier A.R. 9 kHz - 2 GHz typ 29 dB	CPA9231A	3205 / 18564	-----
PEMC 01-039K	ESH3-Z6 V-network 5µH/50ohm LISN 100 kHz - 200 MHz 100A , 600V DC	ESH3-Z6	846422/027	201201796.00
PEMC 01-040K	Active rod antenna 9 kHz - 30 MHz	HFH2-Z6	844857/008	2014020474-1
PEMC 01-041K	RF cable Rod Antenna BNC-BNC	BNC-BNC	None	-----
PEMC 01-042	Power cable rod antenna	12 pin - 12 pin		-
PEMC 01-047	RF Cable magnetic loop antenna			-
PEMC 01-048	Connection cable magnetic loop antenna			-
PEMC 01-049K	RF- Cable Mast-Bilog ant			-----
PEMC 01-052K	Shielded Calibrated Magnetic field pick-up Coil 5 Hz - 10 MHz	HZ-10	847413/020	0
PEMC 01-058K	LOG-PER Antenna 1 GHz ~ 26GHz	HL 025	100193	201201797.00
PEMC 01-059K	Pre-amplifier 1 GHz ~ 26GHz	AFS	937326	201201840.00
PEMC 01-061K	4-WIRE ISN	ENY 41	100192	NA
PEMC 01-069K	Transient Limiter 10 dB (150kHz ... 30MHz)	HZ560	16981196	-

# OVERVIEW TEST RESULTS

Test System : PEMC -01

According standard : FCC15.109 Radiated Emission

		Antenna Polarisation		Requests from customer	Remarks
		Horizontal	Vertical		
<b>Test mode used</b>					
Combined horizontal & Vertical .		X	X		
<b>Used test setup and EUT placement/mode</b>					
1	<a href="#">Set-up according client test plan with EUT 30 ~ 1000MHz</a>	P	P		Powered 120V 60Hz
2		--	--		
3		--	--		
4		--	--		
5		--	--		
6		--	--		
7		--	--		
8		--	--		
9		--	--		
10		--	--		
11		--	--		
12		--	--		
13		--	--		
14		--	--		
15		--	--		

<b>Validation</b>	<input checked="" type="checkbox"/> Hardware	<b>Legend</b>	<input type="checkbox"/> P = Test Pass	<input type="checkbox"/> F = Test Fail
	<input checked="" type="checkbox"/> Software		<input type="checkbox"/> - = Test not performed/input not used	<input type="checkbox"/> X = Used Input

**Measurement Unintentional Radiated Emissions**

**EMC-031-2016**

EUT: PROTO 1286  
Manufacturer: ES Gear Ltd.  
Operating Condition: 120VAC 60Hz  
Test Site: Blue Guide EMC Lab  
Operator: Willems jan  
Test Specification: FCC15.109 Class A 30MHz ~ 1GHz  
Comment: connected to the ethernet  
Start of Test: 5/02/2016 / 12:50:20

**SWEEP TABLE: "FCC15.109"**

Unit: dBµV/m

Detector: Mode:

Curve 1: MaxPeak MaxHold

Subrange 1:

Start Frequency: 30.0 MHz  
Stop Frequency: 1.0 GHz  
Measure Time: 360.0 ms  
IF Bandwidth: 100 kHz

Receiver: ESXI Transducer: CBL61113M  
Signal Path: None System Transducer: None  
Meas. Mode: Lin Add. Transd. 1: AC CP2 (X10) - ANT  
Tracking Gen.: Off Add. Transd. 2: AC CP2 (X10) - RFIN2  
Input: 2DC Add. Transd. 3: PEMC01-038K

**SCAN TABLE: "FCC15.109 30-1000MHz"**

Unit: dBµV/m

Detector: Mode:

Curve 1: QuasiPeak MaxHold

Subrange 1:

Start Frequency: 30.0 MHz Step Size: 50.0 kHz  
Stop Frequency: 1.0 GHz  
Measure Time: 100.0 ms  
IF Bandwidth: 120 kHz

Receiver: ESXI Transducer: CBL61113M  
Signal Path: None System Transducer: None  
Meas. Mode: Lin Add. Transd. 1: AC CP2 (X10) - ANT  
Tracking Gen.: Off Add. Transd. 2: AC CP2 (X10) - RFIN2  
Input: 2DC Add. Transd. 3: PEMC01-038K



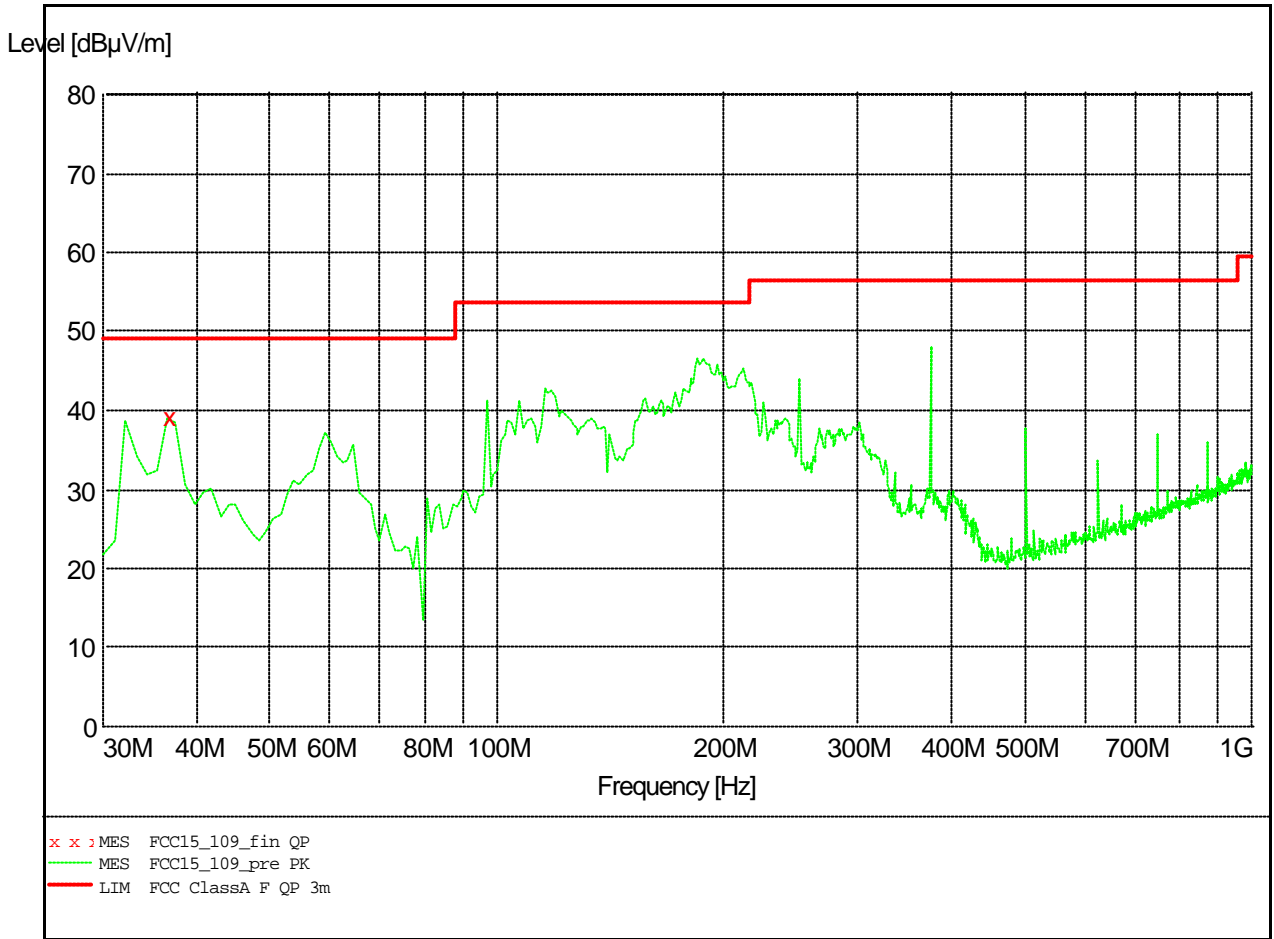

**MEASUREMENT RESULT: "FCC15\_109\_fin QP"**

5/02/2016 13:12

Frequency MHz	Level dBµV/m	Transd dB	Limit dBµV/m	Margin dB	Height cm	Azimuth deg	Polarisation
36.350000	39.30	-12.3	49.0	9.7	100.0	21.00	VERTICAL